

InductCook[®] 220





Original instructions



Operating and assembly manual

Version 11/2021
Article: 8 30 220 00

Description of safety and warning symbols

<p>PLEASE NOTE</p>	<p>Indicates information that is considered important. Used to indicate situations that do not lead to physical injury. For example, information about property damage.</p>
	<p>Read the instructions before using or opening the device.</p>
	<p>This symbol draws your attention to a dangerous situation that will or could result in serious physical injuries or death. Pay attention to appropriate safety precautions.</p>
	<p>Risk – High voltage This dangerous voltage warning symbol indicates a risk of electric shock and hazards from dangerous voltage.</p>
	<p>Electromagnetic field This symbol warns of nonionizing electromagnetic radiation.</p>
	<p>Proper disposal This marking on the product means that the product must not be disposed of with household waste or normal commercial waste. Instead, it should be taken to the collection point responsible for recycling electrical and electronic equipment.</p>

Warnings



If the glass top covering the induction unit shows cracks, disconnect the device from the power supply immediately!



To reduce the risk of fire and electrical shock, DO NOT OPEN THE DEVICE. No user-serviceable parts inside. Repair should be done by Gastros-authorized service personnel only.



Surface remain hot after usage when removing the pan. DO NOT TOUCH!



Content

Warnings.....	2
Content	3
Introduction.....	4
Technical Data	4
Installation / Technical Drawings	5
Operation.....	8
Cleaning, Care, and Disposal	9
Troubleshooting.....	10
Safety Regulations	11
General Information	13

Introduction

The following pages contain important information and advice about the InductCook® 220 device. They explain how to install it, operate it and care for it properly. Please read these operating instructions carefully before using the InductCook® 220 device for the first time. Then store them in a secure place so that you can refer to them quickly if required.

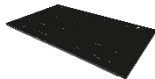
The InductCook® 220 is an induction cooking unit. It is suitable for use in hotels, restaurants, and other fields of the hospitality industry. Besides industrial quality, we also focus on long service life and easy handling.

Delivery Content InductCook® 220		
<i>Article</i>	<i>Description</i>	<i>Article No.:</i>
1	 <p>InductCook® 220 1400W + 2000 W, 240 VAC</p>	1 30 220 00 (CH connector) 1 30 220 01 (EU connector) 1 30 220 02 (US connector) 1 30 220 03 (UK connector)
2	 <p>InductCook® 220 built-in operating and assembly manual</p>	8 30 220 00

Technical Data

Technical information about the InductCook® 220	
Voltage range	220-240 VAC
Power frequency	50/60 Hz
Maximum power	Max. 3400W (left stove: 1400W / right stove 2000 W)
Internal electrical fuse protection	16 A
Dimensions / weight	400 x 681 x 62 mm / 6.3kg

Installation / Technical Drawings

Device dimensions

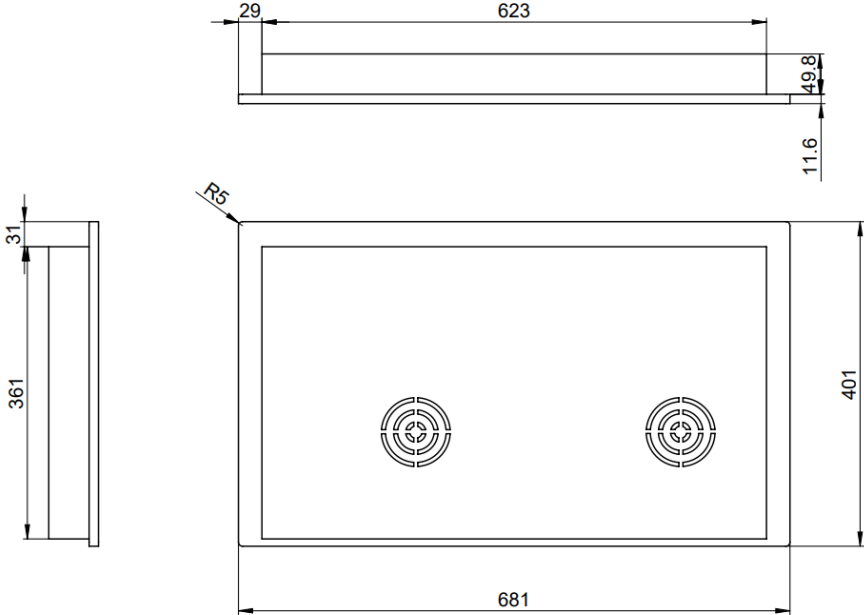

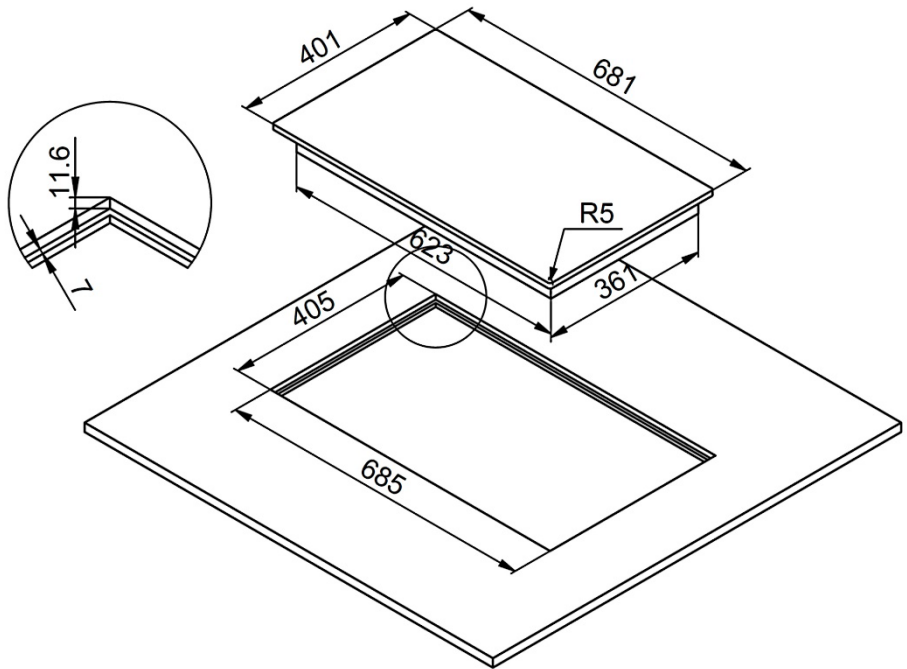

Minimum distance between the elements

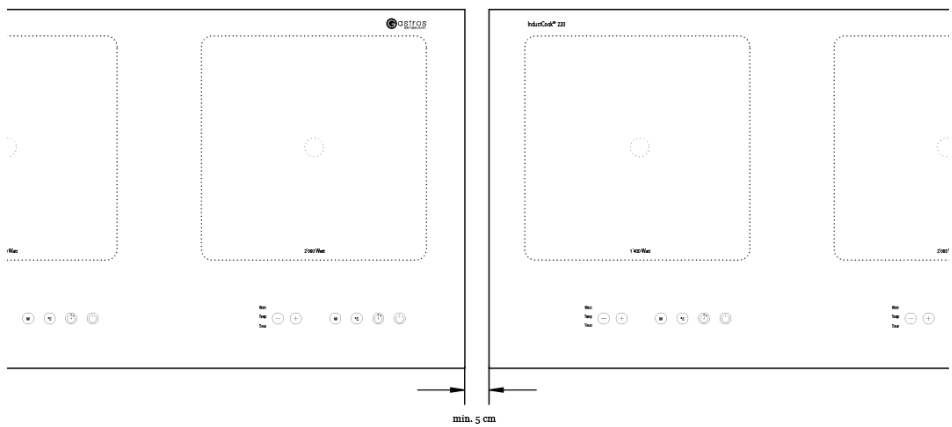

Air circulation



Air circulation openings must not be covered by any other installation parts. The surrounding air must not be higher than 40 °C. The back side fan must have 8.5 cm of open space, and the bottom fan must have 20 cm of open space.

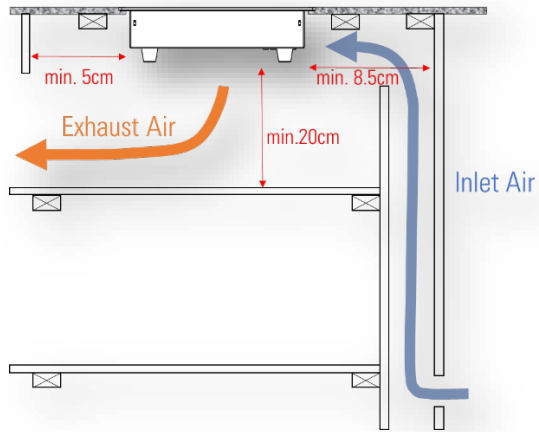

Buffet example

Operation

Connecting the unit to the power:

1. Plug in the power cord.
The buzzer "beeps" shortly and the LCD display is on for 1 second. The device then turns into off mode.

Operate the unit:

1. Place an inductive pot on top of the device.
2. Press "On/Off" button (6) for 3 seconds. The device is now in standby-mode (display: "----").
If there is no action for 30 seconds, the device turns off automatically.
3. Press the "W" or "°C" button to start the device on its default value on level 5 (1'200W / 120°C).

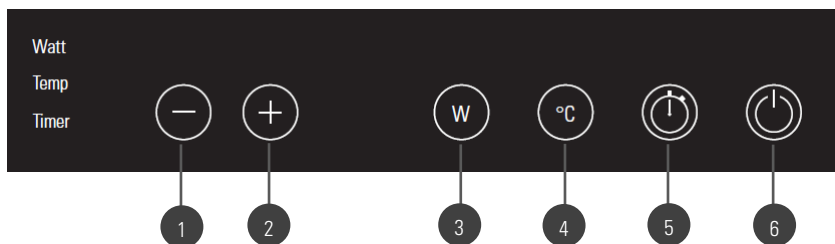

- (1) Reduce power (-)
- (2) Increase power (+)
- (3) Select watts (W)
- (4) Select temperature (°C)
- (5) Timer
- (6) On/Off

Controlling the power:

1. Press "W" or "°C" button to toggle between the "power" (W) and the "temperature"-display (°C)

Level	1	2	3	4	5	6	7	8	9	10
Temp. (°C)	60	80	100	120	140	160	180	200	220	240

Remarks:

The displayed temperature is a reference value only. The real temperature very much depends on the quality of the pot.
Max. output power **LEFT** stove: **1'400W** / Max. output power **RIGHT** stove: **2'000W**

2. Press "+" to increase the power / press "-" to reduce the power
3. If there is no pot on the device (indicated by repeating beep's), the system automatically turns off after 12 seconds.
4. Press "On/Off" button to turn off the device.

Using the timer:

1. Turn on the device as described above.
2. Press the timer-button.
3. Press the "+" and "-" buttons to set the shutdown time (0-180 minutes).
4. After the timer is set, the power can still be controlled by using the "+" and "-" buttons.
5. The device automatically turns off when the time is up.

Cleaning / Maintenance / Disposal

Tips for daily cleaning

- Switch off the InductCook® 220 device. Wait until the device has cooled to hand temperature before starting to clean!
- First, use a scraper to remove all large pieces of dirt and food leftovers from the cooking surface.
- Then squeeze a few drops of a suitable cleaning product on to the cold surface and rub it in with kitchen paper or a clean cloth.
- Finally, remove all cleaning product residue, wipe down the cleaned surfaces with water, and rub dry with a dry cloth.
- Clean the cooking surface regularly, preferably after each use.



Important: If any plastic objects, aluminum foil, sugar, or food containing sugar accidentally melt on to the hot cooking surface, wipe them off the hot cooking zone immediately with a cleaning scraper to prevent surface damage. Never use scouring sponges or scouring products. Chemically aggressive cleaners such as oven spray and stain remover are also unsuitable. Do not use steel wool or sharp objects for cleaning.



This induction cooking device is not splash-water resistant. Therefore, do not use running water or steam to clean it. The device must be protected against water splashes and must not be cleaned with a water jet.

Disposal

This product must be disposed at the recycling centre of electrical and electronic equipment. It must not be disposed of household or normal waste. With the properly disposing you will help prevent potential environmental damage or health hazards. For more information on recycling the product, contact your local municipal office or your waste disposal service.

Devices intended for disposal must not be operated further.



The device consists of electrical, electromechanical, and electronic components. There are no batteries used.



The owner and the operator are responsible for the proper and safe disposal of the device.

Troubleshooting

Error	Possible cause	Elimination of error
No power	No power (no "beep" when connecting the power cord)	Plug the device in, check the plug connection
	Power supply fuse tripped	Check and reset the fuse on the installation side (no fuse on the device)
	Device does not turn on when the button is pressed	Check the plug connection, push the power button again
No heat is generated	Pot is not detected	Pot incorrectly placed -> place the pot exactly within the white frame with the center of the pot located above the white circle
		Pot might be not suitable for induction -> check if the pot is induction-compatible. Only use induction-compatible pots and pans
	Device defective	Contact customer service servicepoint@gastros.swiss
Pot does not get warm enough	Incorrect placement of the pot	Place the pot exactly within the white frame with the center of the pot located above the white circle
	Insufficient energy supply	Increase power or temperature
	Pot is not suitable for induction	Only use induction-compatible pots and pans

Safety Regulations

Responsibility

The InductCook® 220 reflects the state of the art and has been built in accordance with the valid CE guidelines. Safe operation is assured. The InductCook® 220 appliance is not intended to be operated by children or persons with physical or mental limitations, unless they are instructed and monitored while using the appliance by a person responsible for their safety.

The following points must strictly be observed:

- Unauthorized conversions or modifications by the customer are prohibited – Gastros Switzerland AG disclaims all liability in such cases.
- If the mains supply cable for the appliance is damaged, it must be replaced by the manufacturer, an authorized service agent or other similarly qualified person in order to prevent hazards.
- The connection for the mains plug should always be positioned so that it is freely accessible. If this is not possible, a master switch for the appliance must be installed by the customer. In the event of a malfunction, the appliance must be switched off completely by unplugging the mains plug or by turning off the master switch.
- Do not allow any liquid to enter your InductCook® 220 induction appliance. Do not use water jets or steam to clean your InductCook® 220 appliance.



In the event of malfunction or maintenance, the device must be able to be switched off completely by unplugging the mains plug, by operating the main switch or by using the appropriate building fuse with a locking system in the isolated position.

PLEASE NOTE: When transporting, setting up, maintaining, and repairing the InductCook® 220 unit, the latest version of the following regulations and guidelines that are applicable in your country must be observed (list is not exhaustive):

- Regulations of the electrical associations (e.g., VDE, SEV, etc.)
- EC directives (in EU countries)
- Accident prevention regulations
- Guidelines of the employers' liability insurance association
- Trade regulations

If the InductCook® 220 unit is being installed in close proximity to a wall, partition walls, kitchen furniture, decorative paneling, etc., it is recommended, that these objects consist of non-combustible material. Otherwise, they must be covered with a suitable non-combustible, heat-insulating material, and fire safety regulations are to be observed with extreme caution.

Intended use

- The InductCook® 220 is intended for commercial use.
- The InductCook® 220 is not intended for the mass production of food.
- The InductCook® 220 is designed to cook food in induction capable pots/pans. Other usage can destroy the device.
- Only use pots and pans that have been designed as suitable for induction by the manufacturer. Only use cookware with a minimum base diameter of 12 cm. It is possible to use smaller pots and pans, but this may have the following effects:
 - Reduced efficiency
 - Pan recognition may not be possible
 - Radiation may be greater
- Never heat a pot or a pan while empty. This could cause the cookware to overheat.

- Switch off the InductCook® 220 unit if you remove the cookware and do not intend to immediately continue using the device. This will prevent unintentional heating in the event that you or someone else places a pan or pot on the cooking surface.
- Do not heat up tins or other sealed containers, as this can cause an explosion! Items that are unsuitable for use include any dishes that are not specifically intended for induction appliances, as well as metal splash guards, aluminum foil, cutlery, jewelry, watches, metallic objects, etc.
- The surface of the InductCook® 220 appliance should not be used for storage.

Risks



The InductCook® 220 device may represent a source of danger if: (1) the information in these operating instructions is not heeded, (2) setup, maintenance or repair work is undertaken by nonauthorized persons or (3) the InductCook® 220 unit is used incorrectly or for purposes other than its intended use. Other risks may include:

- **Risk of destruction:**
When the induction cooking device is not in use for cooking food, it is crucial to ensure that the device is turned off. Otherwise, damage or burnings may occur as a result.
- **Electrical shock:**
Do not expose this system to liquids or metal objects, as this may cause electric shock.
- **Environmental conditions:**
The system must be mounted in a clean, dry indoor place and the relative humidity must not exceed 60%. To avoid overheating, ensure good ventilation. The environmental temperature must not exceed 40 °C.
- **Risk of burns:**
Cookware used with this device becomes hot during operation and can cause burns. Please use potholders or protective gloves when touching it.



Immediately disconnect the InductCook® 220 from the power net if the glass ceramic cover shows cracks.

If you remove the cookware from the cooking device and no longer want to use it, make sure to switch the device off! Do not rely on the “pot detection” feature.

Do not use metal cutlery, PVC/plastic, aluminum foil, or other metallic objects in combination with the InductCook® 220 device.

It should be noted that finger rings, watches, bracelets, or other jewelry can heat up if they are close to the induction field. This can cause burns.

General Information

Liability

The manufacturer's warranty covers all defects in design, production, and materials. Further claims, including defects due to incorrect operation, are excluded. All data and notes in this manual are prepared with consideration to the statutory standards and regulations. The manufacturer will not be liable for:

- Failure to observe the instructions
- Damages caused by inappropriate handling
- Deployment of unqualified staff
- Unauthorized modification
- Technical modifications
- Use of uncertified spare parts



Please note: Do not use the InductCook® 220 appliance if you notice damage or malfunctions.



If you wear a pacemaker, check with your doctor whether you are allowed near an induction cooking appliance.

Repairs

The top cover of the induction device must not be removed by unauthorized persons and the induction device must not be opened under any circumstances. There are NO user-serviceable parts inside. Repairs may only be carried out by authorized service personnel. Contact your dealer, a trained Gastros Switzerland AG Service Partner, or our customer service department via servicepoint@gastros.swiss.

Unauthorized opening of the device leads to the immediate loss of guarantee/warranty.

Cooking with induction technology

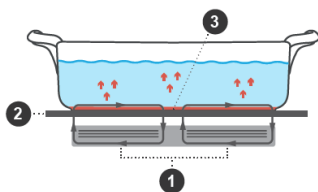

The induction coil (1) located under the glass ceramic top (2) of the device generates an alternating electromagnetic field which, through the eddy current effect, generates heat directly in the bottom (3) of an inductive pot/pan.

Key advantages of using induction technology for hot holding:

- High effectiveness of around 95% – high efficiency – high cooking capacity – minimal power loss
- Ready to be used immediately at full power because electrical energy is converted instantly into heat in the pot's base – no heat-up time
- Low energy consumption compared to electrical cooking systems
- Lower heat radiation compared to other cooking systems = pleasant room climate
- Flat surfaces for easy cleaning and the best possible hygiene
- Lowest operating costs (energy, cleaning, etc.)
- High operational safety thanks to safety electronics

Pots and pans

PLEASE NOTE: Only use induction-capable, appropriately marked cookware.

Incorrect and damaged cookware can be dangerous for the InductCook® 220 device! The use of pans and pots without food can lead to excessive heating of the power electronics and reduce their service life. Also, the cookware itself can be damaged. For example, overheating can cause bulges in the bottom of the cookware. This thereby reduced the ability of the pan or pot to use inductive power.

Using buckled and worn-out cookware is dangerous. Due to the deformation in the bottom, pots and pans cannot lie flat on the surface. Overheating to very high temperatures (until glowing) may not be prevented automatically, which can have serious consequences for the InductCook® 220 device. In the worst case, this may also be consequential to staff members.

The induction cooking device is designed for a certain size range of cookware. Pots and pans within this size range work efficiently well. Under certain circumstances, cookware that is too small cannot be detected. Cookware that is much too large cannot absorb power with the entire bottom surface, and therefore may not reach the desired temperature.

Contact

Gastros Switzerland AG | Buckhauserstrasse 1 | 8048 Zurich / Switzerland
www.gastros.swiss | servicepoint@gastros.swiss

Any information about our product is correct at time of publishing. Differences in colour and shape of pictures, errors and printing errors are reserved. Subject to change without prior notice InductWarm® and the InductWarm® logo are registered trademarks of Gastros Switzerland AG.